



## **Silent Gliss 5100 Autoglide**

### **Fitting Instructions**

## **Fitting Instructions**

### **Content**

- 1) Deciding the position of the track**
- 2) Tools for fixing**
- 3) Top fixing or Overhead Installation**
- 4) Face fixing or Wall installation**

## 1) Deciding the best position

Points to consider when planning your installation.

The 5100 Autoglide may trigger some types of burglar alarm. This can usually be remedied by moving the sensor. If in doubt, consult your burglar alarm supplier.

Also, it may be easiest to have the motor position the same side of the window as the nearest plug socket for ease of installation.

When fixing avoid any hidden cabling in the wall, if in doubt consult a qualified electrician

## Tools for fixing

Your track system is ready assembled for easy fixing. Your track pack includes everything you need to fix the track to a wooden batten.

If fixing directly to a wall or ceiling, appropriate fixings: e.g. wall plugs will also be needed.



## 2) Top Fixing or Overhead Installation

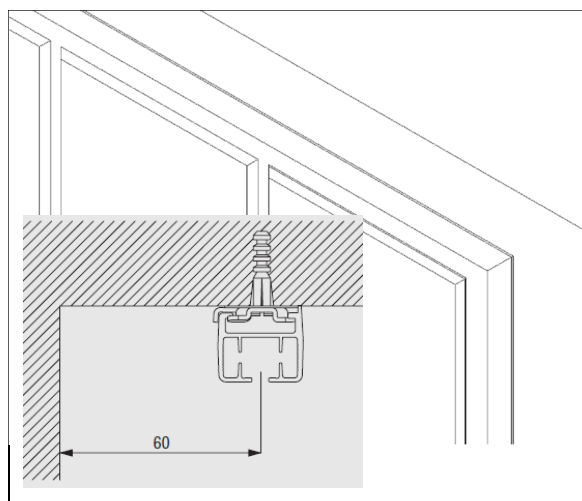

1.

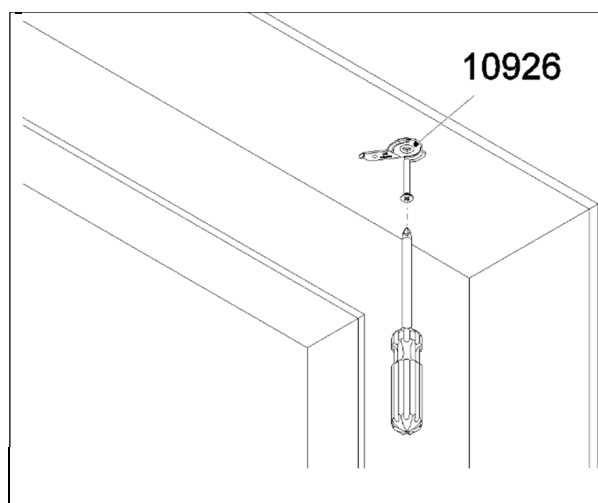

2.

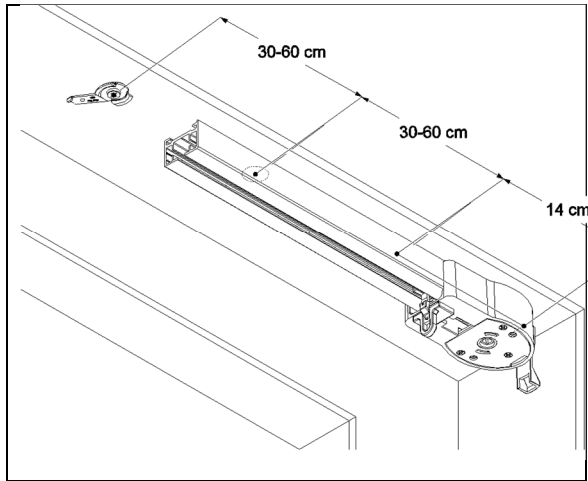

3.

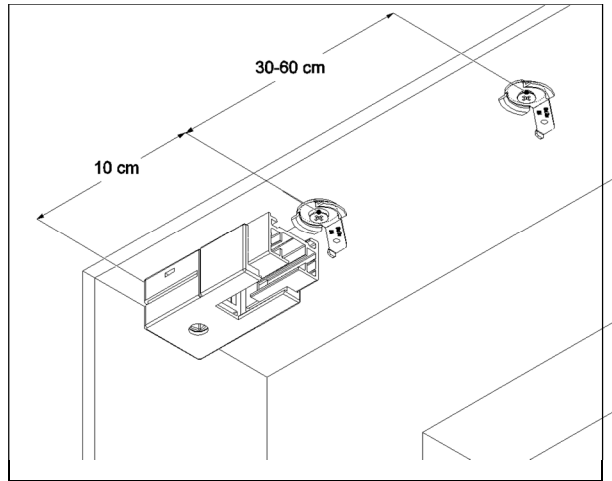

4.

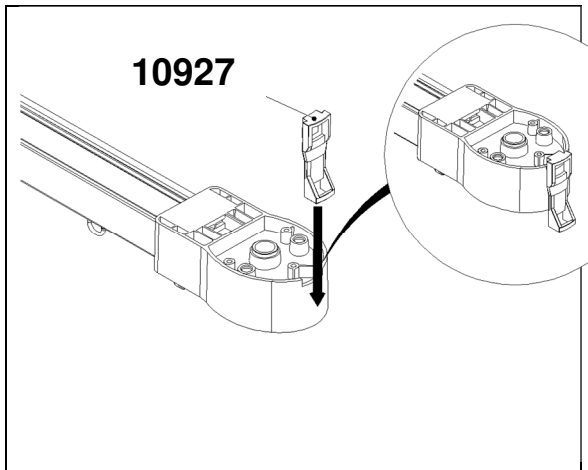

5.

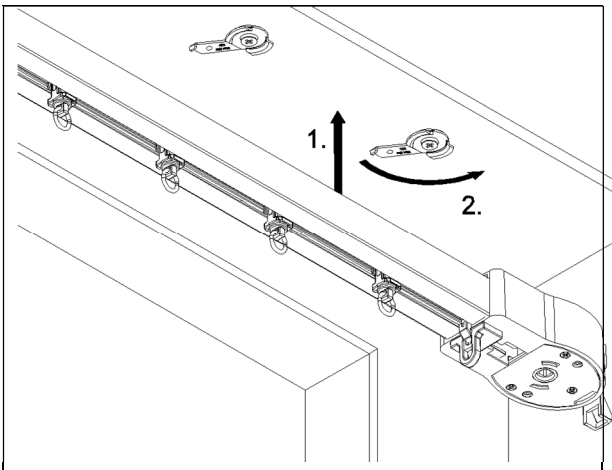

6.

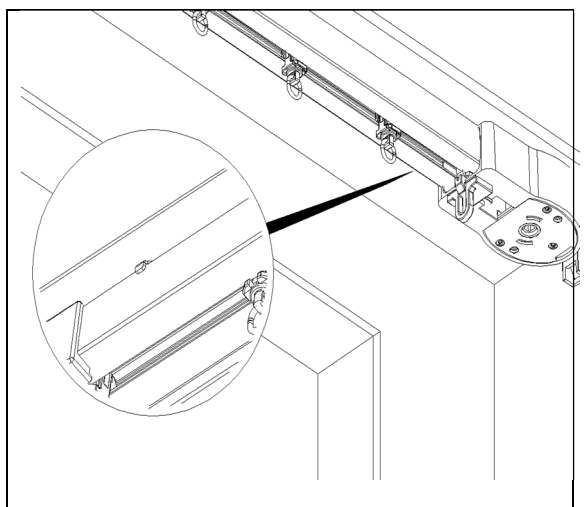

7.

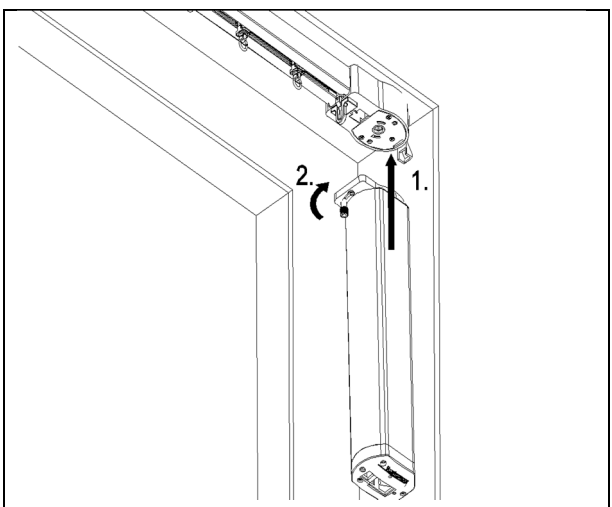

8.

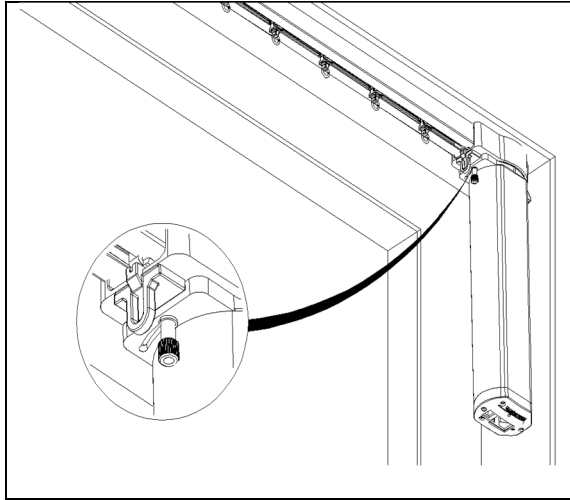

9.

Now plug the motor lead into mains supply

**Note:**

**Refer now to the quick start guide for setting the limits / end positions and assign the controls to the motor**

**3) Face fixing or Wall Installation**

**Fixed Extension bracket**

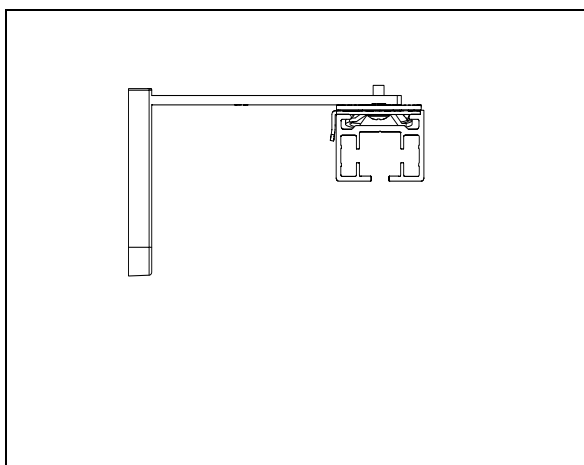

1.

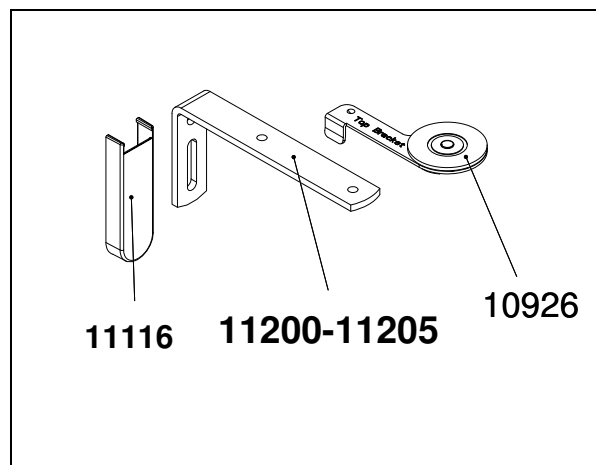

2.

# Face Fix or Wall Installation

## Optional adjustable bracket

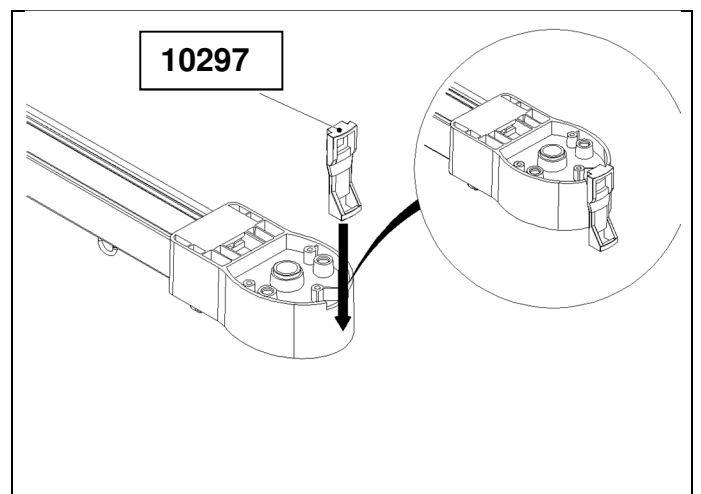
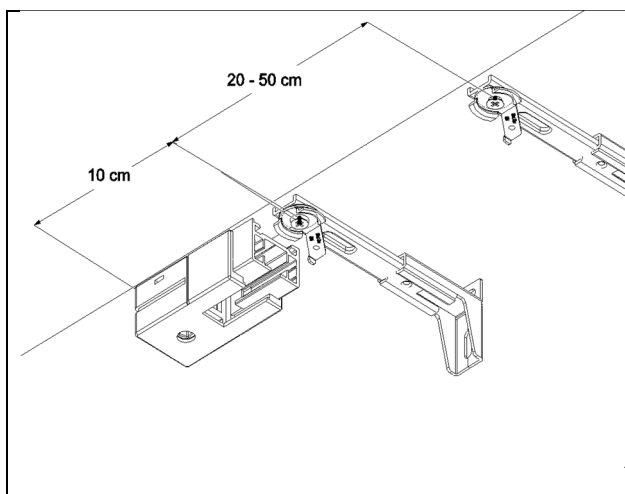
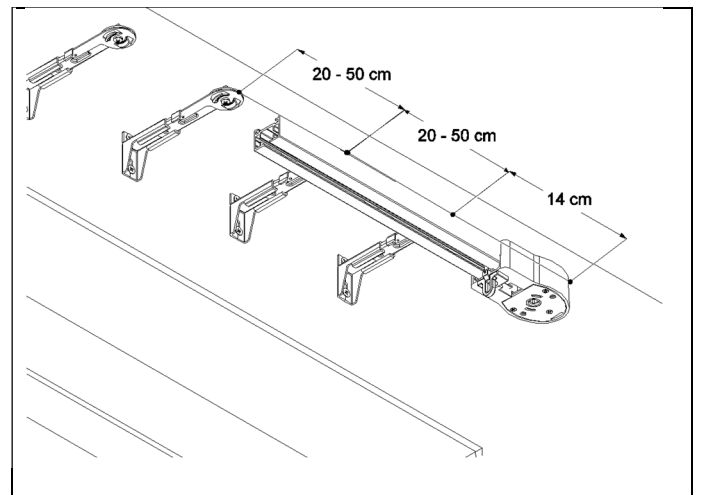
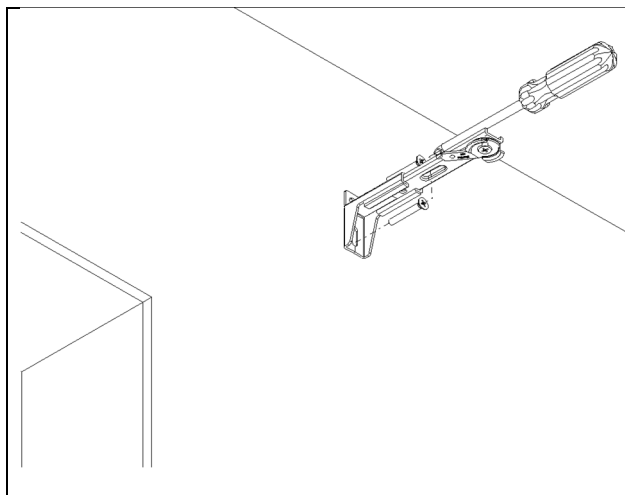
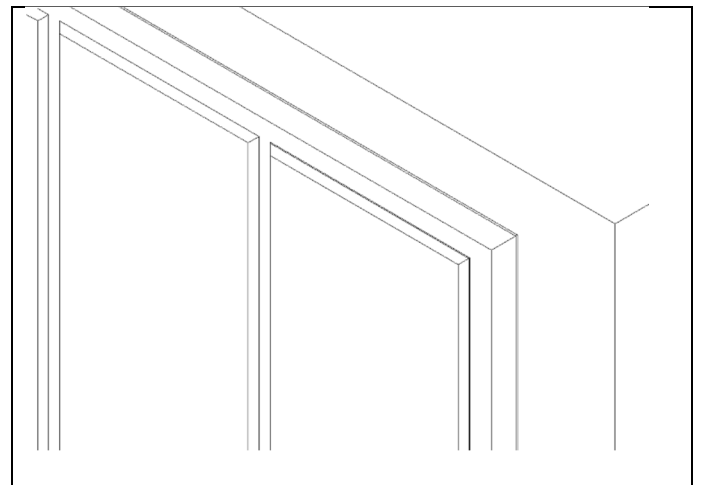
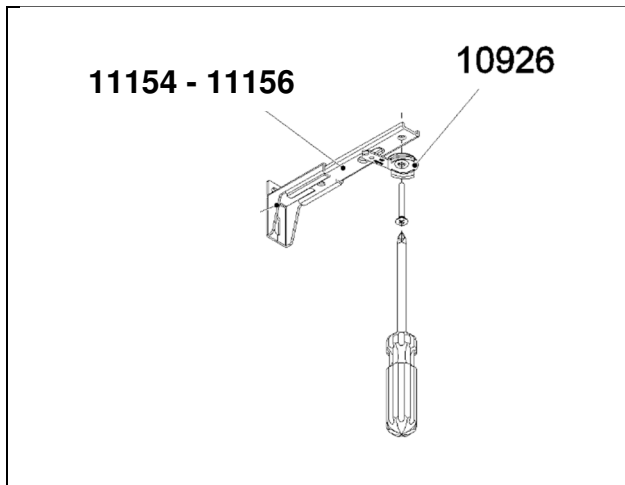

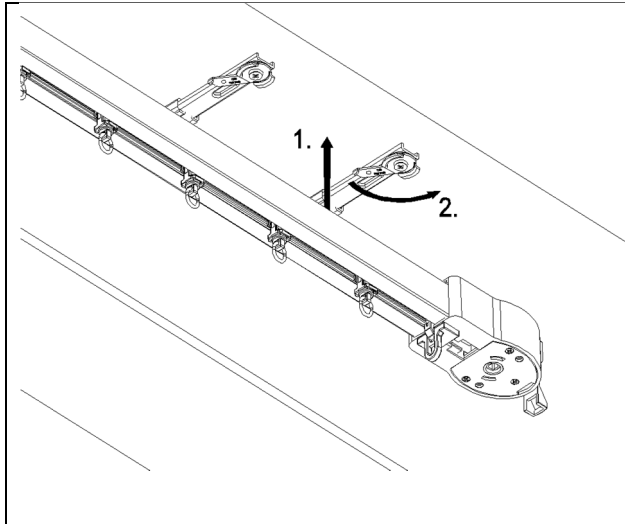

7.

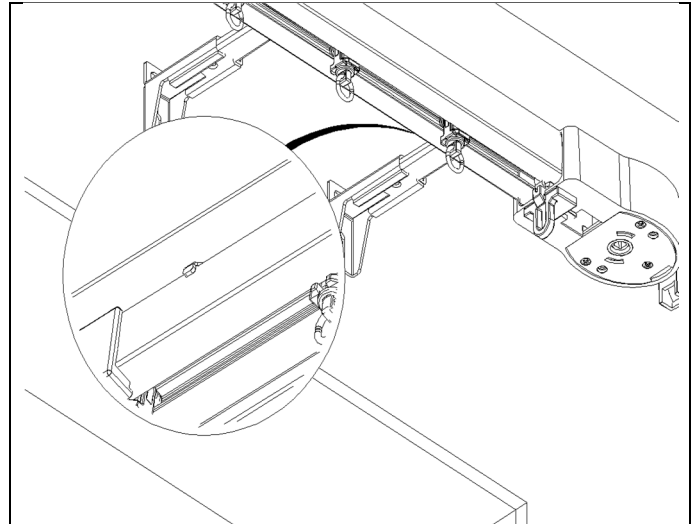

8.

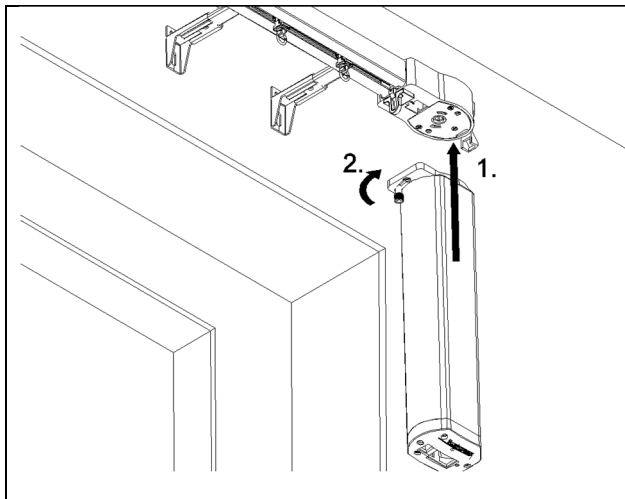

9.

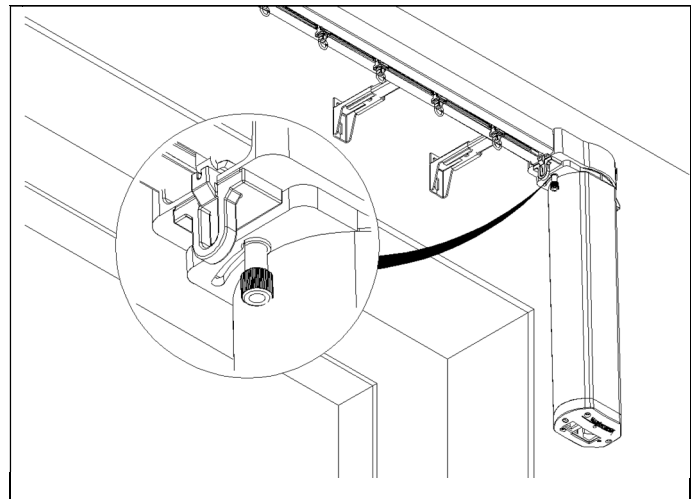

10.

Now plug the motor lead into mains supply

**Note:**

**Refer now to the quick start guide for setting the limits / end positions and assign the controls to the motor**

[www.silentgliss.co.uk](http://www.silentgliss.co.uk)

Silent Gliss Limited  
Pyramid Business Park  
Poorhole Lane  
Broadstairs  
Kent CT10 2PT

Telephone: 01843 863571  
Fax: 01843 864503  
[info@silentgliss.co.uk](mailto:info@silentgliss.co.uk)