



**Silent Gliss 5100 Autoglide**  
**Quick Start Guide**



# Quick Start Guide

## Contents

### **1. System options**

5100B - Base

5100R - Remote

5100T – Timer

5100TC – Total Control

### **2. Limit setting**

All options

### **3. Assigning controls to motors**

5100B - Base

5100R - Remote

5100T – Timer

5100TC – Total Control

### **4. Trouble shooting**

## 1. 5100 Autoglide - System Options

### 5100B – Base



System 5100B standard control with radio wall switch, comprising of :

Motor 5190

Wall switch 10949

### 5100R - Remote



System 5100R can be controlled by wall switch or remote control handset comprising of :

Motor 5190

Wall Switch 10949

Handset 10946

## 5100T - Timer



System 5100T can be controlled by wall switch or timer unit comprising of :

Motor 5190

Wall Switch 10949

Timer 11092

## 5100TC - Total Control



System 5100TC can be controlled by wall switch, remote handset or Timer unit comprising of :

Motor 5190

Wall Switch 10949

Handset 10946

Timer 11092

## 2. Setting the Limits (end positions)

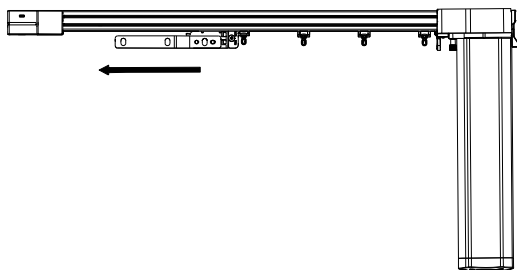
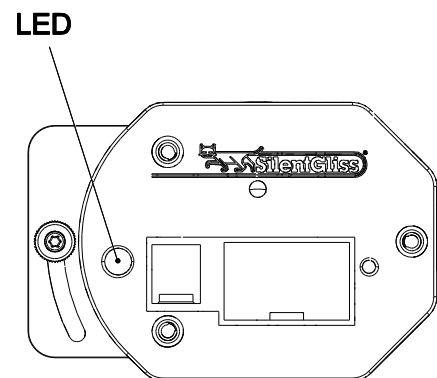
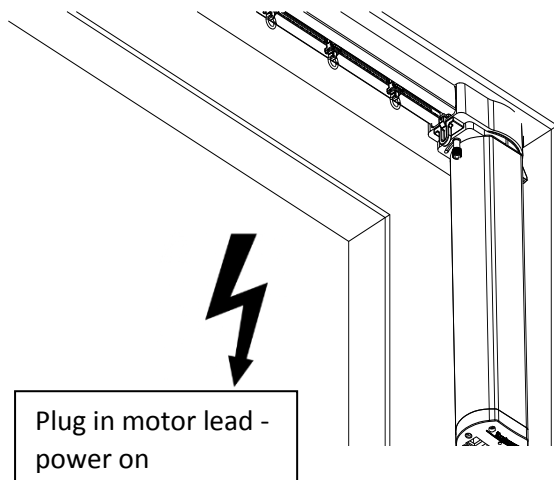

1. Pull curtain in one direction for 15 cm and then let go
2. Curtain moves in this direction until the end
3. LED blinks three times blue
4. First end position is set

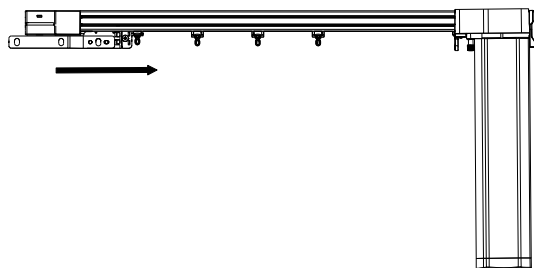

1. Pull curtain in other direction for 15 cm and then let go
2. Curtain moves in other direction until the end
3. LED flashes three times blue
4. Second end position is set

## Re-Setting limits (re-positioning end positions)

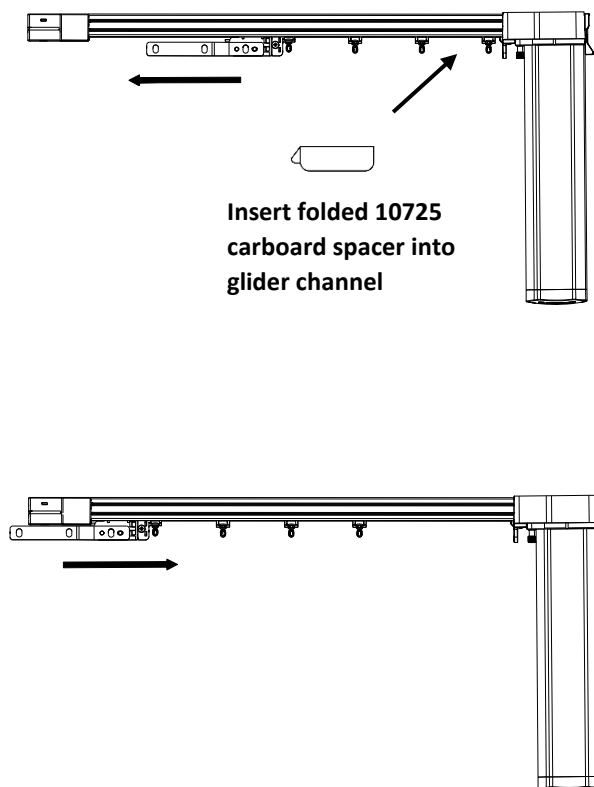

### Changing the limits due to stacking requirements

1. Disconnect Power (Power off) for 10 sec.
2. LED flashes blue twice
3. Insert the cardboard spacer 10725 provided into the glider channel behind the overlap arm to pack out to the desired stacking width
4. Power on
5. Pull curtain in one direction for 15 cm and then let go
6. LED flashes 3 x blue
7. Pull curtain in other direction for 15 cm then let go
8. LED flashes 3 x blue
9. Limits re-set

Please note your 5100 Autoglide is equipped with touch and go and manual override.

Now the limits are set it is possible to operate the curtains by simply pulling the leading edge of either curtain 15 cm in the desired direction, the curtain will then move to the limit in that direction.

If there is a power failure it is possible to move the curtains manually to open and close without damaging the track or motor.

However, it will mean the first movement made in either direction after the power failure will re-set the limits to the extreme ends, here any adjusted limit position set prior to the power failure will be lost. Therefore the adjusted position will need to be reset as per the steps above (Re-Setting limits).

Please note, unplugging the power supply means that the limits need to be re-set as above.

### 3. Assigning Controls to the motor

All controls are radio control so will need assigning to the motor on the track – for each system option follow the steps below after the limits (end positions) have been set on the motor.

#### 5100B - Base – Wall switch 10949

##### On the motor

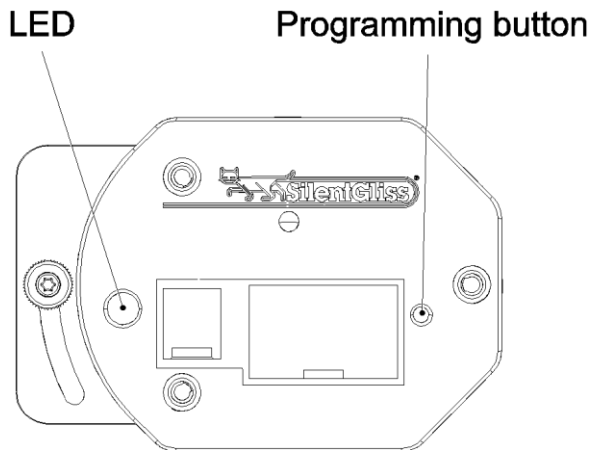

1. Push programming button with a pin for 1 sec
2. LED blinks red
3. Please follow the steps below on the wall switch within the next 10 seconds

##### On the wall switch

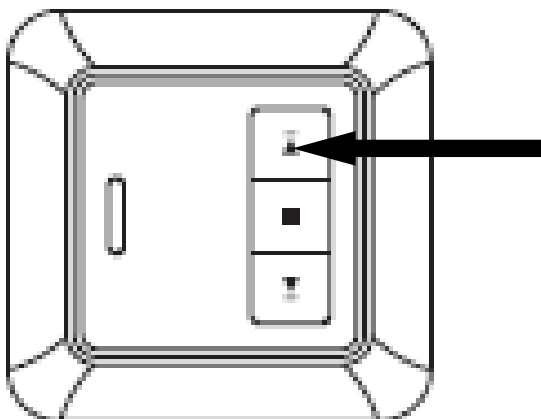

1. Press UP on wall switch
2. LED on motor blinks 3 times blue
3. Wall switch now assigned
4. For any further instructions refer to the instruction manual in wall switch package.

**Full instructions for the radio wall switch 10949 are enclosed with the unit.**

**5100R - Remote – Handset 10946**

**On motor**

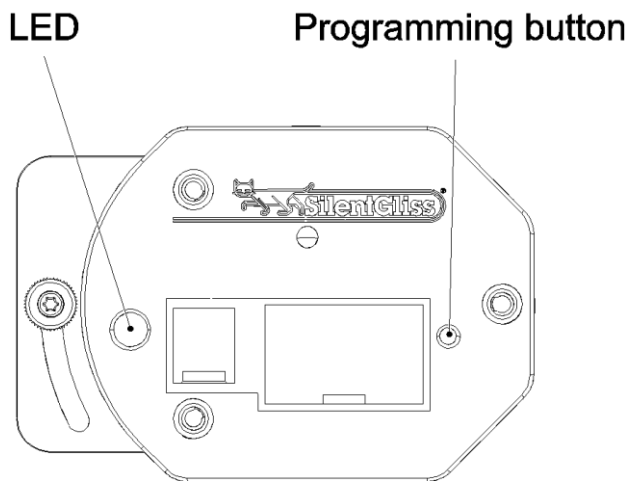

1. Push programming button with a pin for 1 sec.
2. LED blinks red
3. Please follow the steps below on the handset within the next 10 seconds

**On Handset 10946**

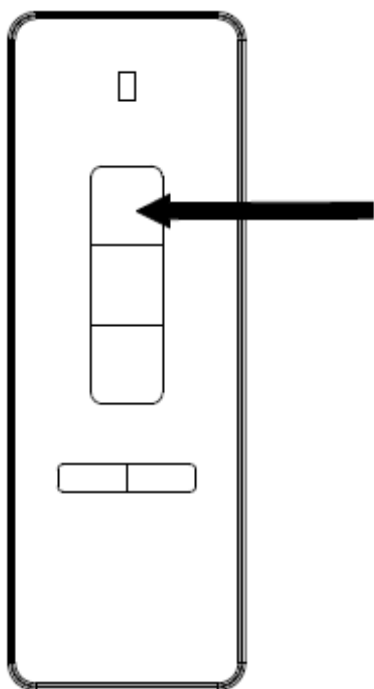

1. Press UP on handset
2. LED on motor blinks 3 times blue
3. Handset now assigned
4. For any further instructions refer to the instruction manual in wall plate package

**Full instructions for the handset 10946 are enclosed with the unit.**



## 5100T - Timer – 11092

### On Motor

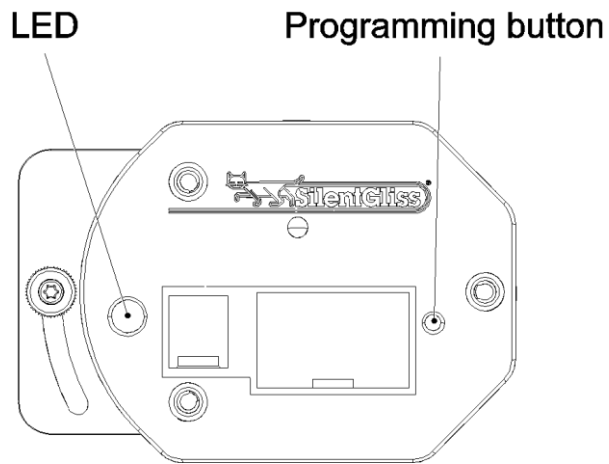

1. Push programming button with a pin for 1 sec
2. LED blinks red
3. Please follow the steps below on the timer within the next 10 seconds.

### On timer 11092

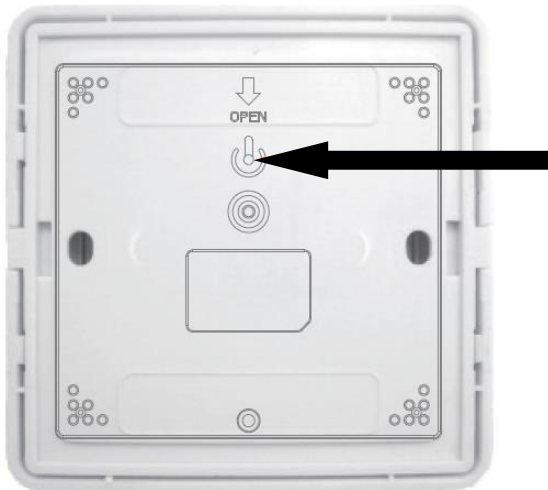

1. To Activate timer press power button on rear of unit approx. 1 sec with a pin.

## On Timer

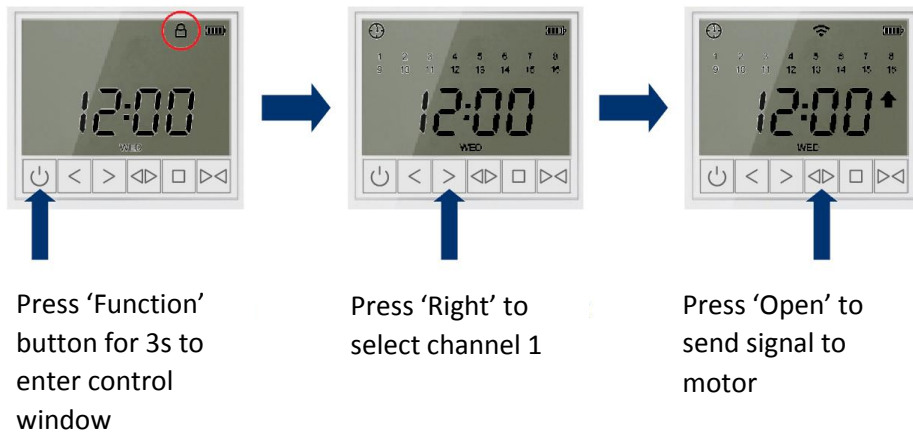

The timer is now assigned.

**Full instructions for setting the timer are enclosed with the 11092 timer unit.**

## 5100TC – Total control

The 5100T uses each method of control Wall Plate, Handset and Timer, to assign each please follow the steps as per the instructions above for each unit.

## Trouble shooting

Possible fault	Possible cause	Elimination of fault
... during group circuit via power line no motor turns		Verify that the phase is connected to each motor
... the motor with permanent power supply does not rotate		Program the end positions again to ensure that the end positions are programmed
... the motor cannot be programmed with the radio transmitter		Make sure that the radio transmitter is programmed
... the motor stops again after a short start-up	System is not assembled correctly	Check system Reprogram the end positions

[www.silentgliss.co.uk](http://www.silentgliss.co.uk)

Silent Gliss Limited  
Pyramid Business Park  
Poorhole Lane  
Broadstairs  
Kent CT10 2PT

Telephone: 01843 863571

Fax: 01843 864503

[info@silentgliss.co.uk](mailto:info@silentgliss.co.uk)